

Channel Assignment for Wireless Networks Modelled as d -dimensional Square Grids

Aniket Dubhashi, Shashanka MVS, Amrita Pati, Shashank R.
Birla Institute of Technology & Science
Pilani, India
{f1999011,f1999154,f1999013,f1999025}@bits-pilani.ac.in

Anil M. Shende¹
Roanoke College
Salem, VA, USA
email: shende@roanoke.edu
Tel: +1 540 774 0866
FAX: +1 540 389 4236

Keywords: Wireless networks, channel assignment, algorithms, lattices, grids

¹Communicating author

Channel Assignment for Wireless Networks Modelled as d -dimensional Square Grids

Abstract

In this paper, we study the problem of channel assignment for wireless networks modelled as d -dimensional grids. In particular, for d -dimensional square grids, we present optimal assignments that achieve a channel separation of 2 for adjacent stations where the reuse distance is 3 or 4. We also introduce the notion of a colouring schema for d -dimensional square grids, and present an algorithm that assigns colours to the vertices of the grid satisfying the schema constraints.

1 Introduction

The enormous growth of wireless networks has made the efficient use of the scarce radio spectrum important. A “Frequency Assignment Problem” (FAP) models the task of assigning frequencies (channels) from a radio spectrum to a set of transmitters and receivers, satisfying certain constraints [8]. The main difficulty in an efficient use of the radio spectrum is the *interference* caused by unconstrained simultaneous transmissions. Interferences can be eliminated (or at least reduced) by means of suitable *channel assignment* techniques, which partition the given radio spectrum into a set of disjoint channels that can be used simultaneously by the stations while maintaining acceptable radio signals. Since radio signals get attenuated over distance, two stations in a network can use the same channel without interferences provided the stations are spaced sufficiently apart. Stations that use the same channel are called *co-channel stations*. The minimum distance at which a channel can be reused with no interferences is called the *co-channel reuse distance* (or simply *reuse distance*) and is denoted by σ .

In a *dense* network – a network where there are a large number of transmitters and receivers in a small area – interference is more likely. Thus, reuse distance needs to be high in such networks. Moreover, channels assigned to nearby stations must be separated in value by at least a gap which is inversely proportional to the distance between the two stations. A minimum *channel separation* δ_i is required between channels assigned to stations at distance i , with $i < \sigma$, such that δ_i decreases when i increases [7]. The purpose of channel assignment algorithms is to assign channels to transmitters in such a way that (1) the co-channel reuse distance and the channel separation constraints are satisfied, and (2) the *span* of the assignment, defined to be the difference between the highest and the lowest channels assigned, is as small as possible [2].

In this paper, we investigate the channel assignment problem, described informally above, for networks that can be modelled as grids in d dimensions, $d \geq 3$. In Section 3 we define the infinite d -dimensional square and cellular grids, and show that a solution for the channel assignment problem for the d -dimensional square (cellular) grid places an upper bound on solutions for the problem for a suitable d' -dimensional cellular (square) grid. These results partly motivate our study of the channel assignment problem in higher dimensional grids. Another motivation is that when the networks of several service providers overlap geographically, they must use different channels for their clients. The overall network can then be modelled in a suitably higher dimension.

The main focus of the paper is a study of the problem for networks arranged as d -dimensional square grids. We consider the restricted problem requiring a channel separation of 1 for all but adjacent stations, and a larger (than 1) separation for adjacent stations. In Section 4, we present optimal assignments for d -dimensional square grids for $\sigma = 3, 4$ with a channel separation constraint of 2 for adjacent stations. Finally, in Section 4.5, we introduce the notion of a colouring schema for d -dimensional square grids and present an algorithm that assigns colours to the vertices of the grid satisfying the schema constraints.

2 Preliminaries

Formally, the *channel assignment problem with separation* (CAPS) can be modelled as an appropriate colouring problem on an undirected graph $G = (V, E)$ representing the network topology, whose vertices in V correspond to stations, and edges in E correspond to pairs of stations that can hear each other’s transmission [2]. For a graph G , we will denote the distance between any two vertices in the graph, i.e., the number of edges in a shortest path between the two vertices, by $d_G(\cdot, \cdot)$. (When the context is clear, we will denote the distance as simply $d(\cdot, \cdot)$.) CAPS is then defined as:

CAPS $(G, \sigma, \vec{\delta})$

Given an undirected graph G , an integer $\sigma > 1$, and a vector of positive integers $\vec{\delta} = (\delta_1, \delta_2, \dots, \delta_{\sigma-1})$, find an integer $g > 0$ so that there is a function $f : V \rightarrow \{0, \dots, g\}$, such that for all $u, v \in G$, for each i , $1 \leq i \leq \sigma - 1$, if $d(u, v) = i$, then $|f(u) - f(v)| \geq \delta_i$.

This assignment is referred to as a g - $L(\delta_1, \delta_2, \dots, \delta_{\sigma-1})$ colouring of the graph G [6], and **CAPS** $(G, \sigma, \vec{\delta})$ is sometimes referred to as the $L(\vec{\delta})$ colouring problem for G . Note that a g - $L(\delta_1, \delta_2, \dots, \delta_{\sigma-1})$ uses only the $(g+1)$ colours in the set $\{0, \dots, g\}$, but does *not* necessarily use all the $(g+1)$ colours. A g - $L(\delta_1, \delta_2, \dots, \delta_{\sigma-1})$ colouring of G is *optimal* iff g is the smallest number witnessing a solution for **CAPS** $(G, \sigma, \vec{\delta})$.

Finding the optimal colouring for general graphs has been shown to be *NP*-complete. The problem remains *NP*-complete even if the input graphs are restricted to planar graphs, bipartite graphs, chordal graphs, and split graphs [4]. Most of the work on this problem has dealt with specific graphs such as grids and rings, for small reuse distance (σ) values, and for small channel separation (δ_i) values, e.g., optimal $L(1, 1)$ colourings for rings and bidimensional grids [1], optimal $L(2, 1)$ and $L(2, 1, 1)$ colourings for hexagonal, bidimensional, and cellular grids [2], etc. Recently, Bertossi et al [3] exhibited optimal $L(\delta_1, 1, \dots, 1)$ colourings, for $\delta_1 \leq \lfloor \sigma/2 \rfloor$, for bidimensional grids and rings. (See [3] for a succinct literature survey of this problem.) Below, we refer to $L(\cdot, 1, \dots, 1)$ colourings by $L(\cdot, \vec{1}_k)$ colourings.

As pointed out in [2], a lower bound for the $L(1, \vec{1}_k)$ colouring problem is also a lower bound for the $L(\delta, \vec{1}_k)$, $\delta > 1$. Given an instance of **CAPS**, consider the augmented graph obtained from G by adding edges between all those pairs of vertices that are at a distance of at most $\sigma - 1$. Clearly, then, the size (number of vertices) of any clique in this augmented graph places a lower bound on an $L(1, \vec{1}_{\sigma-1})$ colouring for G ; the best such lower bound is given by the size of a maximum clique in the augmented graph.

In each graph, G , for each σ , we identify a canonical sub-graph, $T(G, \sigma)$, of the graph so that the vertices of $T(G, \sigma)$ induce a clique in the augmented graph of the graph. We will refer to $T(G, \sigma)$ as a *tile*. When the context is clear, we will refer to the size of $T(G, \sigma)$ simply as $c(\sigma)$.

Most (but not all) of the assignment schemes described in this paper follow the pattern: for a given graph G , and for a given σ , (1) identify $T(G, \sigma)$, (2) find the number of vertices in $T(G, \sigma)$, and hence a lower bound for the given assignment problem, (3) describe a colouring scheme to colour all the vertices of $T(G, \sigma)$, (4) demonstrate a tiling of the entire graph made up of $T(G, \sigma)$ to show that the colouring scheme described colours the entire graph, and (5) show that the colouring scheme satisfies the given reuse distance and channel separation constraints.

3 Channel Assignments in Higher Dimensional Grids

In this section we relate $L(\delta_1, \delta_2, \dots, \delta_{\sigma-1})$ colourings for d -dimensional cellular and square grids.

For any d -dimensional lattice, \mathcal{L} , the minimal distance in the lattice is denoted by $\mu(\mathcal{L})$. The infinite graph, denoted $\mathcal{G}(\mathcal{L})$, corresponding to the lattice \mathcal{L} consists of the set of lattice points as vertices; each pair of lattice points that are at a distance $\mu(\mathcal{L})$ constitute the edges of $\mathcal{G}(\mathcal{L})$. Henceforth, we will not make a distinction between the lattice points in \mathcal{L} and the corresponding vertices in $\mathcal{G}(\mathcal{L})$. For any lattice \mathcal{L} , for any two points u and v in \mathcal{L} , $d_{\mathcal{G}(\mathcal{L})}(\cdot, \cdot)$ will denote the distance between vertices u and v in $\mathcal{G}(\mathcal{L})$.

The lattice \mathbf{Z}^d is the set of ordered d -tuples of integers, and \mathbf{A}_d is the hyperplane that is a subset of \mathbf{Z}^{d+1} , and is characterised as the set of points in \mathbf{Z}^{d+1} such that the coordinates of each point add up to zero. $\mu(\mathbf{Z}^d) = 1$, and the minimal length vectors in \mathbf{Z}^d are the unit vectors in each dimension. For each $d > 0$, for each $i, j, 0 \leq i, j \leq d, i \neq j$, define $\lambda_{ij}^d = (x_0, \dots, x_d)$ where $x_i = 1, x_j = -1$, and for each $k, 0 \leq k \leq d, k \neq i, j, x_k = 0$. Then, $\mu(\mathbf{A}_d) = \sqrt{2}$, and the set of minimal length vectors in \mathbf{A}_d is $\{\lambda_{ij}^d \mid i, j, 0 \leq i, j \leq d, i \neq j\}$. (See [5, 9] for more on these lattices.)

The infinite d -dimensional square grid is, then, $\mathcal{G}(\mathbf{Z}^d)$, and the infinite d -dimensional cellular grid is $\mathcal{G}(\mathbf{A}_d)$.

Theorem 1. *For all $d \geq 2$, if there is a g - $L(\delta_1, \delta_2, \dots, \delta_{\sigma-1})$ colouring for \mathbf{Z}^d , then there is a g - $L(\gamma_1, \gamma_2, \dots, \gamma_{\lfloor \frac{\sigma}{2} \rfloor - 1})$ colouring for \mathbf{A}_{d-1} where, for each $i, 1 \leq i \leq \lfloor \frac{\sigma}{2} \rfloor - 1, \gamma_i = \delta_{2i}$.*

Proof. Consider a point $x = (x_0, \dots, x_{d-1})$ that is in the intersection of \mathbf{Z}^d and \mathbf{A}_{d-1} . Then, $d_{\mathbf{Z}^d}(x, 0) = 2 \cdot d_{\mathbf{A}_{d-1}}(x, 0)$, thus giving us the theorem. \square

Theorem 2. *For all $n \geq 2$, if there is a g - $L(\delta_1, \delta_2, \dots, \delta_{\sigma-1})$ colouring for \mathbf{A}_d , then there is a g - $L(\delta_1, \delta_2, \dots, \delta_{\sigma-1})$ colouring for $\mathbf{Z}^{\lfloor \frac{d+1}{2} \rfloor}$.*

Proof. Consider the subset of minimal length vectors in \mathbf{A}_d given by $\{\lambda_{i(d-i)}^d \mid 0 \leq i < \lfloor \frac{d+1}{2} \rfloor\}$. Clearly, this subset consists of $\lfloor \frac{d+1}{2} \rfloor$ mutually orthogonal vectors, and hence is a basis for $\mathbf{Z}^{\lfloor \frac{d+1}{2} \rfloor}$. Thus, the infinite graph for $\mathcal{G}(\mathbf{Z}^{\lfloor \frac{d+1}{2} \rfloor})$ is a subgraph of $\mathcal{G}(\mathbf{A}_d)$, and hence the result. \square

4 Colourings for $\mathcal{G}(\mathbf{Z}^d)$

As mentioned in Section (1), we first identify the canonical sub-graph $T(\mathcal{G}(\mathbf{Z}^d), \sigma)$, and then find lower bounds on the colourings of $\mathcal{G}(\mathbf{Z}^d)$. We then present optimal colouring schemes for $\mathcal{G}(\mathbf{Z}^d)$, for $\sigma = 3, 4$, with a separation constraint of 2 for adjacent vertices. We introduce the notion of a colouring schema for $\mathcal{G}(\mathbf{Z}^d)$, and also prove that the colouring schemes presented have running times of $O(d)$.

4.1 Lower bound

The lower bound on the colouring of $\mathcal{G}(\mathbf{Z}^d)$ is the number of vertices in $T(\mathcal{G}(\mathbf{Z}^d), \sigma)$, denoted by $c(\sigma)$. Henceforth, we will refer to this number by $n(\sigma, d)$. Note that $n(\sigma, 1) = \sigma$. It can be proved that:

$$n(\sigma, d) = n(\sigma, d-1) + 2 \sum_{i=1}^{\lfloor \frac{\sigma}{2} \rfloor} n(\sigma - 2i, d-1).$$

4.2 Colouring Strategy

Before we present the actual colouring schemes, we present an intuitive discussion of the strategy that we will use to colour $\mathcal{G}(\mathbf{Z}^d)$.

We will use the notation $(x_0, \dots, x_i, \dots, x_{d-1})$ to denote the vertex in $\mathcal{G}(\mathbf{Z}^d)$. The strategy used to colour $\mathcal{G}(\mathbf{Z}^d)$ is to identify a *base-segment* on a *baseline*. The baseline is the set of vertices $(x_0, 0, \dots, 0)$. The base-segment is the set of vertices $(x_0, 0, \dots, 0)$ with $0 \leq x_0 \leq B(\sigma, d)$, where $B(\sigma, d)$ is the number of colours used to colour $\mathcal{G}(\mathbf{Z}^d)$, with a reuse distance of σ . Note that $B(\sigma, d) \leq n(\sigma, d)$, as $n(\sigma, d)$ is the lower bound on the colouring. This base-segment is *translated* to fill up $\mathcal{G}(\mathbf{Z}^d)$. A translation of the base-segment into the i^{th} dimension is an increase in x_0 , and an increment of 1 in the i^{th} dimension. A translation, in other words is to repeat the colouring at some distance. The increase in x_0 is given by the translation function t_i , where $1 \leq i \leq d-1$.

We thus have a function f that colours vertices on the baseline, and a function C that colours vertices of $\mathcal{G}(\mathbf{Z}^d)$. To prove that our colouring schema work, we will make use of a process called *dimensional collapse*, which is the inverse of the translation process described above. It is the strategy of reducing the colours assigned to arbitrary vertices in $\mathcal{G}(\mathbf{Z}^d)$ to colours assigned to vertices on the baseline. We describe the process here.

Consider two vertices $P = (x_0, x_1, \dots, x_{d-1})$ and $Q = (x'_0, x'_1, \dots, x'_{d-1})$ in $\mathcal{G}(\mathbf{Z}^d)$, where $x'_i - x_i = k_i$, $0 \leq i \leq d-1$. Let t_i be the translation function employed by a colouring scheme C for $\mathcal{G}(\mathbf{Z}^d)$. The colours assigned to P and Q will be:

$$C(P) = C(x_0, x_1, \dots, x_{d-1}) = C(x_0 - \sum_{i=1}^{d-1} x_i \cdot t_i, 0, \dots, 0), \text{ and } C(Q) = C(x'_0 - \sum_{i=1}^{d-1} x'_i \cdot t_i, 0, \dots, 0).$$

This means the colours assigned to P and Q are the same as the colours assigned to vertices $u = (x_0 - \sum_{i=1}^{d-1} x_i \cdot t_i, 0, \dots, 0)$ and $v = (x'_0 - \sum_{i=1}^{d-1} x'_i \cdot t_i, 0, \dots, 0)$ on the baseline. We call u and v the *collapse points* corresponding to P and Q . Their *collapse positions* are $CP(P)$ and $CP(Q)$ respectively. We define the *collapse distance* as the distance between u and v . We denote it by $CD(P, Q)$.

$$CD(P, Q) = d(u, v) = |k_0 - \sum_{i=1}^{d-1} k_i \cdot t_i|$$

4.3 Optimal colouring for $\sigma = 3$

Consider the *star* graph S_Δ which consists of a *center* vertex c with degree Δ , and Δ ray vertices of degree 1. We will use the following Lemma about the colouring of S_Δ , proved in [2].

Lemma 1. [2] *Let the center c of S_Δ be already coloured. Then, the largest colour required for a g - $L(2, 1)$ -colouring of S_Δ by the colouring function f is at least:*

$$g = \begin{cases} \Delta + 1 & f(c) = 0 \text{ or } f(c) = \Delta + 1, \\ \Delta + 2 & 0 < f(c) < \Delta + 1. \end{cases}$$

□

Consider any induced subgraph in $\mathcal{G}(\mathbf{Z}^d)$, with the distance between the vertices $d(u, v) \leq \sigma - 1$. This is a *star* graph with a center vertex of degree $2d$ and $2d$ ray vertices, each of degree 1. There are instances of the star graph where $0 < f(c) < \Delta + 1$. Hence we have from Lemma (1):

Lemma 2. *If there is a g - $L(2, 1)$ colouring of $\mathcal{G}(\mathbf{Z}^d)$, then $g \geq 2d + 2$.*

□

Lemma (2) shows that $n(\sigma, d) \geq 2d + 3$. We provide a colouring scheme that uses $B(\sigma, d) = 2d + 3$ colours. The base-segment is coloured using the function:

$$f(x_0) = \begin{cases} 2d - 2x_0 + 1 & x_0 \bmod (2d + 3) \leq d, \\ 4d - 2x_0 + 4 & d + 1 \leq x_0 \bmod (2d + 3) \leq 2d + 2. \end{cases} \quad (1)$$

We define in Equation (2) the colouring scheme C_3 , and later prove that it optimally colours $\mathcal{G}(\mathbf{Z}^d)$:

$$\begin{aligned} C_3(x_0, x_1, \dots, x_i, 0, \dots, 0) &= C_3(x_0 - (i + 1)x_i, x_1, \dots, x_{i-1}, 0, \dots, 0), 1 \leq i \leq d - 1, \\ C_3(x_0, 0, \dots, 0) &= f(x_0). \end{aligned} \quad (2)$$

We make the following observations about the colours assigned to the baseline:

Lemma 3. *For colouring the baseline,*

1. *The set of $2d + 3$ colours used by the function f defined in Equation (1) is $\{0, 1, \dots, 2d + 2\}$.*
2. *Vertices are assigned consecutive colours iff they are $((d + 1) \bmod (2d + 3))$ or $((d + 2) \bmod (2d + 3))$ apart.*
3. *The difference in colours assigned to consecutive vertices is at least two.*
4. *For distinct vertices u and v on the baseline, $d(u, v) \neq 2d + 3 \implies f(u) \neq f(v)$.*

□

Here, we prove that the colouring scheme C_3 is optimal:

Theorem 3. *The colouring defined by C_3 is an optimal $L(2, 1)$ colouring of $\mathcal{G}(\mathbf{Z}^d)$.*

Proof. From Lemma (3.1), the colouring scheme C_3 uses exactly $2d + 3$ colours, with the largest colour being $2d + 2$. From Lemma (2), this scheme is optimal if it *works*. To prove that C_3 works, we have to prove that it satisfies the co-channel reuse and the channel separation constraints.

Adherence to the co-channel reuse constraint: Suppose two distinct vertices $P = (x_0, x_1, \dots, x_{d-1})$ and $Q = (y_0, y_1, \dots, y_{d-1})$ in $\mathcal{G}(\mathbf{Z}^d)$ are assigned the same colour. Then, the co-channel reuse constraint is satisfied if we prove that $d(P, Q) \geq 3$. Let us assume the contrary, i.e. $d(P, Q) \leq 2$.

Case 1: *P and Q differ in x_0 .*

When P and Q differ in x_0 , we write P and Q as follows:

$$P = (x_0, x_1, \dots, x_a, \dots, x_{d-1}), \text{ and } Q = (x'_0, x_1, \dots, x'_a, \dots, x_{d-1}),$$

where $1 \leq a \leq d - 1$, $x'_0 - x_0 = k_0$, and $x'_a - x_a = k_a$, $1 \leq |k_0| + |k_a| \leq 2$, $|k_0| > 0$.

Performing the *dimensional collapse* on P and Q , we get:

$$\begin{aligned} CP(P) &= (x_0 - dx_{d-1} - \dots - (a + 1)x_a - \dots - 2x_1, 0, \dots, 0), \\ CP(Q) &= (x'_0 - dx_{d-1} - \dots - (a + 1)x'_a - \dots - 2x_1, 0, \dots, 0) \\ CD(P, Q) &= |k_0 - (a + 1)k_a| \end{aligned}$$

Since the maximum value of a is $d - 1$, we have: $0 < |k_0 - (a + 1)k_a| \leq d + 1$. This means that there are two vertices u and v on the baseline such that $C_3(u) = C_3(P)$ and $C_3(v) = C_3(Q)$, and $0 < d(u, v) \leq d + 1$. From Lemma (3.4), $C_3(u) \neq C_3(v)$. Therefore, $C_3(P) \neq C_3(Q)$, giving us a contradiction.

Case 2: P and Q do not differ in x_0 .

In this case, we write P and Q as follows:

$$P = (x_0, x_1, \dots, x_a, \dots, x_b, \dots, x_{d-1}), \text{ and } Q = (x_0, x_1, \dots, x'_a, \dots, x'_b, \dots, x_{d-1}), \text{ where} \quad (3)$$

$$1 \leq a \leq d-1 \text{ and } 1 \leq b \leq d-1,$$

$$x'_a - x_a = k_a \text{ and } x'_b - x_b = k_b, 1 \leq |k_a| + |k_b| \leq 2. \quad (4)$$

Performing the dimensional collapse on P and Q , we get:

$$CD(P, Q) = |-(a+1)k_a - (b+1)k_b|. \quad (5)$$

From Equations (3) and (4), and from the fact that $a \neq b$, we have: $0 < CD(P, Q) \leq 2d$. Therefore we have $0 < d(u, v) \leq 2d$. From Lemma (3.4), $C_3(u) \neq C_3(v)$. Therefore, $C_3(P) \neq C_3(Q)$, giving us a contradiction.

The above two cases thus prove that $d(P, Q) \geq 3$, thereby satisfying the co-channel reuse constraint.

Adherence to the channel separation constraint: To prove the channel separation constraint, we use Lemma (3.2). As before, it suffices to verify the following two cases:

Case 1: P and Q differ in x_0 .

This is a special case of Case 1 of the previous argument with $|k_0| = 1$ and $k_a = 0$. Performing the dimensional collapse on P and Q as before, we get $CD = 1$. From Lemma (3.2), u and v , and hence P and Q cannot have consecutive colours.

Case 2: P and Q do not differ in x_0 .

This is also a special case of Case 2 of the previous argument, with $|k_a| = 1$ and $k_b = 0$. From Equations (3) and (5), we have $0 < CD \leq d$, i.e. $0 < d(u, v) \leq d$. From Lemma (3.2), u and v , and hence P and Q cannot have consecutive colours. \square

4.4 Optimal colouring for $\sigma = 4$

The lower bound for $L(2, 1, 1)$ colouring is $n(4, d) = 4d$. Hence, $B(4, d) \geq 4d$. We use the following Lemma, proved in [2], about the span of an $L(\delta_1, 1, \dots, 1)$ colouring. For the graph $G(V, E)$, [2] also defines $\lambda(G)$ as the largest colour used in an optimal colouring scheme.

Lemma 4. [2] Consider the $L(\delta_1, 1, \dots, 1)$ -colouring problem, with $\delta_1 \geq 2$, on a graph $G = (V, E)$ such that $d(u, v) < \sigma$ for every pair of vertices u and v in V . Then $\lambda(G) = |V| - 1$ if and only if \overline{G} has a Hamiltonian path. \square

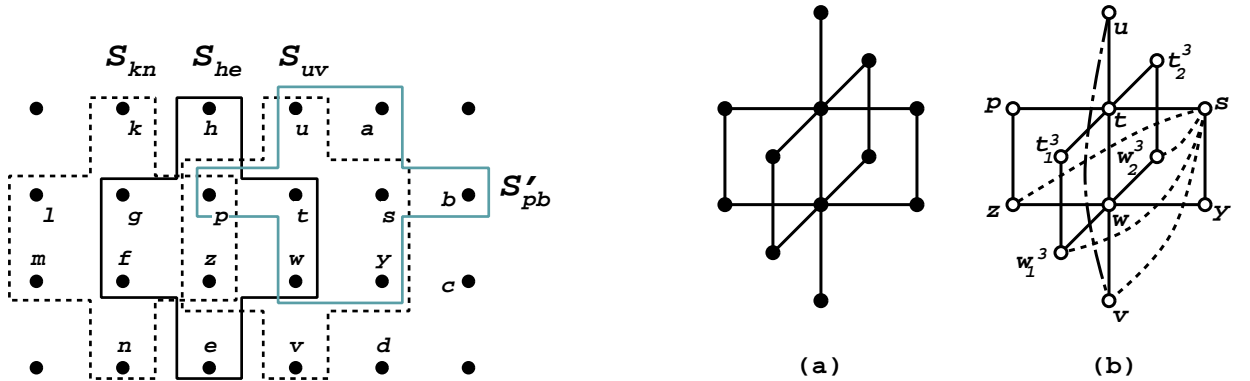

Figure 1: A plane in $\mathcal{G}(\mathbb{Z}^d)$, (a) Induced subgraph M in $\mathcal{G}(\mathbb{Z}^3)$, and (b) Dummy edges in M

In [2], Lemma (4) is used to prove the existence of a hole in $L(2, 1, 1)$ colouring of $\mathcal{G}(\mathbb{Z}^2)$. Lemma (5) extends the proof to $\mathcal{G}(\mathbb{Z}^d)$.

Lemma 5. *If there is a g -L(2, 1, 1) colouring of $\mathcal{G}(\mathbf{Z}^d)$, then $g \geq 4d$.*

Proof. Consider a plane in $\mathcal{G}(\mathbf{Z}^d)$ characterised by $(x_0, x_1, k_2, k_3, \dots, k_{d-1})$, where the first two coordinates can vary and k_i 's are fixed constants. Such a plane is shown in Figure 1. For any vertex x in this plane, x_1^i and x_0^i denote vertices above the plane of the paper and x_2^i and x_3^i denote vertices below the plane of the paper. The subscripts 1 and 0 denote distances of 1 and 2 above the plane of the paper respectively. Similarly, the subscripts 2 and 3 denote distances of 1 and 2 below the plane of the paper respectively. The superscript i denotes the dimension of the vertex, where $(3 \leq i \leq d)$. Consider the set of vertices which make up the induced subgraph $T(\mathcal{G}(\mathbf{Z}^d), \sigma)$ denoted by M for notational convenience (illustrated in Figure 1a for three dimensions) in $\mathcal{G}(\mathbf{Z}^d)$ with distance between any two vertices less than the reuse distance 4:

$$S_{uv} = \{u, t, w, v, p, z, s, y, t_1^i, t_2^i, w_1^i, w_2^i\}, \text{ and } S'_{pb} = \{p, t, s, b, u, a, w, y, t_1^i, t_2^i, s_1^i, s_2^i\}$$

The points $\{a, b, s_1^i, s_2^i\}$ are adjacent to s . Consider the set of vertices in S'_{pb} . Once S_{uv} has been assigned to all different colours, the vertices $\{a, b, s_1^i, s_2^i\}$ of S'_{pb} must be assigned the colours assigned to the vertices $\{z, v, w_1^i, w_2^i\}$ if only $4d$ colours $\{0, 1, \dots, 4d-1\}$ are to be used. Due to the channel separation constraint, colours assigned to $\{a, b, s_1^i, s_2^i\}$ must be at least two apart from the colour assigned to vertex s . This is equivalent to adding dummy edges connecting s to $\{z, v, w_1^i, w_2^i\}$ in M induced by S_{uv} . Figure 1b shows these dummy edges in M in $\mathcal{G}(\mathbf{Z}^3)$. Repeating this argument for vertices y, z and p we get the dummy edges connecting y to $\{p, u, t_1^i, t_2^i\}$, z to $\{u, s, t_1^i, t_2^i\}$ and p to $\{y, v, w_1^i, w_2^i\}$ in S_{uv} . These edges are not shown in the Figure 1b to avoid cluttering.

Now consider the sets S_{uv} and S_{he} . Four vertices p, t, w and z are common between them and their colours are fixed. The remaining vertices $\{h, g, f, e, p_1^i, p_2^i, z_1^i, z_2^i\}$ of S_{he} should be assigned the colours assigned to $\{u, s, y, v, t_1^i, t_2^i, w_1^i, w_2^i\}$ in S_{uv} . We are interested in the vertices u and v in S_{uv} . We want to prove that a colouring of $\mathcal{G}(\mathbf{Z}^d)$ satisfying all constraints implies a dummy edge uv in S_{uv} . For this, we will fix the colour of v (denoted by $C(v)$) in S_{he} and consider all vertices where colour of u (denoted by $C(u)$) can reoccur and prove that we can always find a set $S'_{u,v}$ in which colours of u and v are assigned to adjacent vertices. Note that due to the co-channel reuse constraint, $C(v)$ can reoccur at h, g, p_1^i or p_2^i in S_{he} and for each of these positions of v , $C(u)$ can reoccur at f, e, z_1^i or z_2^i in S_{he} . Note that for any recurrence of $C(v)$, if $C(u)$ reoccurs at e then $C(u)$ and $C(v)$ are assigned to adjacent vertices e and v respectively. This implies a dummy edge between u and v in S_{uv} . Consider the following cases for each recurrence of $C(v)$ when $C(u)$ does not reoccur at e .

Case 1: $C(v)$ reoccurs at h in S_{he} .

Here, $C(u)$ and $C(v)$ are assigned to adjacent vertices u and h respectively. This implies a dummy edge between u and v in S_{uv} .

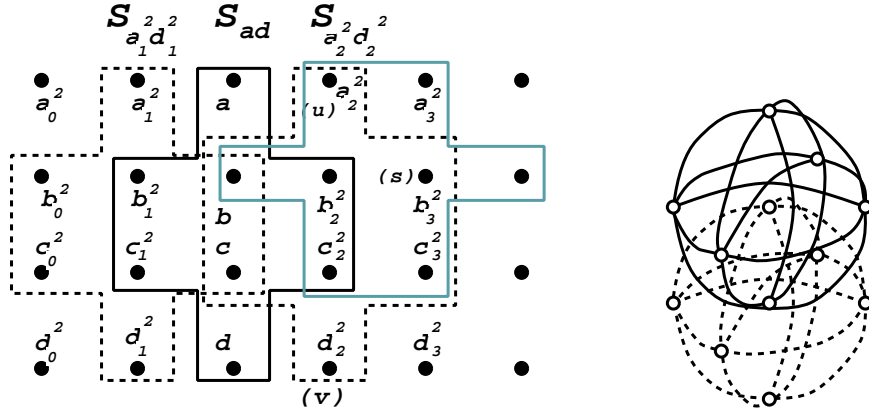

Figure 2: New nomenclature for vertices in Figure 1, and \overline{M} in $\mathcal{G}(\mathbf{Z}^3)$.

Case 2: $C(v)$ reoccurs at g, p_1^i or p_2^i in S_{he} .

To treat this case conveniently, we introduce a new nomenclature for the vertices in the plane. Figure 2 shows the new nomenclature where the vertices a, d, a_2^2 and d_2^2 correspond to vertices h, e, u and v

respectively. As before, the superscripts denote the dimensions, with $i = 2$ for vertices in the plane. This case can be broken down into the following two cases.

Case 2a: $C(v)$ reoccurs at b_1^i and $C(u)$ reoccurs at c_1^i .

Without loss of generality, consider the case when $i = 2$. Here, $C(u)$ and $C(v)$ are assigned to adjacent vertices b_1^2 and c_1^2 respectively. This implies a dummy edge between u and v in S_{uv} .

Case 2b: $C(v)$ reoccurs at b_1^i and $C(u)$ reoccurs at c_1^j , where $i \neq j$ and $2 \leq i, j \leq d$.

Without loss of generality, let $C(v)$ reoccur at b_1^2 . Consider the set $S_{a_1^2 a_2^2}$. In this set, let $b_1^2 = x$ for convenience. Due to co-channel reuse constraint, $C(u)$ at c_1^i can reoccur in $S_{a_1^2 a_2^2}$ at one of b_0^2, a_1^2, x_1^i or x_2^i all of which are adjacent to b_1^2 coloured with $C(v)$.

The above two cases show that no matter where $C(u)$ and $C(v)$ reoccur in S_{he} we can always find a set $S_{u'v'}$ in which $C(u)$ and $C(v)$ are assigned to adjacent vertices. Hence we have a dummy edge connecting u and v in S_{uv} as shown in Figure 1b.

Finally, let us build \overline{M} , the complement of M . Figure 2 shows \overline{M} in $\mathcal{G}(\mathbf{Z}^3)$ and Figure 1a shows M in $\mathcal{G}(\mathbf{Z}^3)$. Since \overline{M} consists of two connected components, \overline{M} cannot contain a Hamiltonian path. Hence by Lemma (4), there is no g - $L(2, 1, 1)$ colouring for $\mathcal{G}(\mathbf{Z}^d)$ with $g = 4d - 1$. \square

We shall use the previous strategy of colouring the base-segment and translating it to fill up $\mathcal{G}(\mathbf{Z}^d)$. Here, for the i^{th} dimension, $t_i = 4i - 1$ and The base-segment is the set of vertices $(x_0, 0, \dots, 0)$ with $0 \leq x_0 \leq 4d - 1$. The base-segment is coloured using the function:

$$f(x_0) = \begin{cases} x_0 \bmod 4 & x_0 \bmod 4 = 0, \\ d + (x_0 \bmod 4) & x_0 \bmod 4 = 2, \\ 2d + 1 + (x_0 \bmod 4) & x_0 \bmod 4 = 3, \\ 3d + 1 + (x_0 \bmod 4) & x_0 \bmod 4 = 1. \end{cases} \quad (6)$$

We now define the colouring scheme C_4 , and later prove that it optimally colours $\mathcal{G}(\mathbf{Z}^d)$:

$$\begin{aligned} C_4(x_0, x_1, \dots, x_i, 0, \dots, 0) &= C_4(x_0 - (4i - 1)x_i, x_1, \dots, x_{i-1}, 0, \dots, 0), 1 \leq i \leq d - 1 \\ C_4(x_0, 0, \dots, 0) &= f(x_0 \bmod 4d). \end{aligned} \quad (7)$$

We make the following observations about the colouring of the baseline:

Lemma 6. *For colouring the baseline,*

1. The set of $4d$ colours used by the function f defined in Equation (6) is $\{0, 1, \dots, 2d - 1, 2d + 1, \dots, 4d\}$.
2. The difference in colours assigned to consecutive vertices (vertices differing in x_0 by 1) is at least two.
3. For distinct vertices u and v in the same base-segment, $f(u) \neq f(v)$. \square

Lemma 7. *On the baseline, the following is true about vertices that are assigned consecutive colours:*

1. If they are assigned the colours $2d + 3$ and $2d + 4$, then they are 2 apart.
2. If they are not assigned the colours $2d + 3$ and $2d + 4$, then they are $4k$ apart, where $k \neq 0, k \in \mathbb{I}$. \square

Here, we prove that the colouring scheme C_4 is optimal.

Theorem 4. *The colouring defined by C_4 is an optimal $L(2, 1, 1)$ colouring of $\mathcal{G}(\mathbf{Z}^d)$.*

Proof. From Lemma (6.1), the colouring scheme C_4 uses exactly $4d$ colours, with the largest colour being $4d$. From Lemma (5), this scheme is optimal if it satisfies the co-channel reuse and the channel separation constraints.

Adherence to the co-channel reuse constraint: Suppose two distinct vertices $P = (x_0, x_1, \dots, x_{d-1})$ and $Q = (y_0, y_1, \dots, y_{d-1})$ in $\mathcal{G}(\mathbf{Z}^d)$ have the same colour assigned to them. Then, the co-channel reuse constraint is satisfied if we prove that $d(P, Q) \geq 4$. Let us assume the contrary, i.e. $d(P, Q) \leq 3$.

Case 1: P and Q differ in x_0 .

When P and Q differ in x_0 , we write P and Q as follows:

$$\begin{aligned} P &= (x_0, x_1, \dots, x_a, \dots, x_b, \dots, x_{d-1}), \text{ and } Q = (x'_0, x_1, \dots, x'_a, \dots, x'_b, \dots, x_{d-1}), \\ \text{where } 1 \leq a \leq d-1, \quad 1 \leq b \leq d-1, \quad x'_0 - x_0 &= k_0, x'_a - x_a = k_a, x'_b - x_b = k_b, \\ 1 \leq |k_0| + |k_a| + |k_b| &\leq 3, \quad |k_0| > 0. \end{aligned} \quad (8)$$

A dimensional collapse on P and Q will in this case give

$$CD(P, Q) = |k_0 - (4a-1)k_a - (4b-1)k_b| = |-4s+t|, \text{ where } s, t \in I, \quad s = (ak_a + bk_b), \quad t = (k_0 + k_a + k_b). \quad (9)$$

In Equation (9), if $t \neq 0$, then by Equation (8), $CD(P, Q) > 0$. Also, since $t \neq 0$, CD is not a multiple of 4. By Lemma (6.1), $C_4(u) \neq C_4(v)$ and hence $C_4(P) \neq C_4(Q)$, giving us a contradiction.

If $t = 0$, we have $k_0 + k_a + k_b = 0$, which is only possible when $\{|k_0|, |k_a|, |k_b|\} = \{1, 0, 1\}$ or $\{1, 1, 0\}$. Therefore, $CD = d(u, v) = 4a$ or $4b$. Since the maximum values that a and b can take are $(d-1)$, by Lemma (6.1), $C_4(u) \neq C_4(v)$ and $C_4(P) \neq C_4(Q)$, giving us a contradiction.

Case 2: P and Q do not differ in x_0 .

In this case, we write P and Q as follows:

$$\begin{aligned} P &= (x_0, \dots, x_a, \dots, x_b, \dots, x_c, \dots, x_{d-1}), \text{ and } Q = (x_0, \dots, x'_a, \dots, x'_b, \dots, x'_c, \dots, x_{d-1}), \\ \text{where } 1 \leq a, b, c \leq d-1, \quad x'_a - x_a &= k_a, \quad x'_b - x_b = k_b, \quad x'_c - x_c = k_c, \\ 1 \leq |k_a| + |k_b| + |k_c| &\leq 3. \end{aligned}$$

Performing the dimensional collapse on P and Q as before, we get:

$$\begin{aligned} CD(P, Q) &= |-(4a-1)k_a - (4b-1)k_b - (4c-1)k_c| = |-4s+t|, \quad s, t \in I, \\ s &= ak_a + bk_b + ck_c, \quad t = k_a + k_b + k_c. \end{aligned} \quad (10)$$

If $t \neq 0$, then by the argument used in the previous case, $C_4(P) \neq C_4(Q)$ —a contradiction.

If $t = 0$, $k_a + k_b + k_c = 0$, which is possible only when $\{k_a, k_b, k_c\} = \{0, 1, -1\}$, or $\{0, -1, 1\}$ or $\{1, 0, -1\}$ or $\{-1, 0, 1\}$ or $\{0, 1, -1\}$ or $\{0, -1, 1\}$. Without loss of generality, we can say: $d(u, v) = 4|s| = 4(a-b)$. Since $a-b$ is not a multiple of $4d$, $d(u, v)$ is not a multiple of $4d$, and by the previous argument, $C_4(P) \neq C_4(Q)$ —a contradiction.

The above two cases thus prove that $d(P, Q) \geq 4$, thereby verifying the co-channel reuse constraint.

Adherence to the channel separation constraint: As before, it suffices to verify the following two cases:

Case 1: P and Q differ in x_0 .

This is a special case of Case 1 of the previous argument with $|k_0| = 1, k_a = k_b = 0$. This means that there are two vertices u and v on the baseline such that $C_4(u) = C_4(P)$ and $C_4(v) = C_4(Q)$, and $d(u, v) = 1$. From Lemma (7), u and v , and hence P and Q cannot have consecutive colours.

Case 2: P and Q do not differ in x_0 .

This is also a special case of Case 2 of the previous argument, with $|k_a| = 1$ and $k_b = k_c = 0$. We have $d(u, v) = 4a-1$. From Lemma (7), u and v , and hence P and Q cannot have consecutive colours. \square

4.5 Colouring Schema for \mathbf{Z}^d

In this section we present a generalized scheme for $L(\delta_1, \vec{1}_{\sigma-2})$ colourings of $\mathcal{G}(\mathbf{Z}^d)$ for all d and odd values of σ . Towards this, we first introduce the notion of a *colouring schema for \mathbf{Z}^d* . We then show the existence of such schema. Then we present an algorithm that uses such a colouring schema for \mathbf{Z}^d , for colouring $\mathcal{G}(\mathbf{Z}^d)$, and prove that the resulting colouring is an $L(\delta_1, \vec{1}_k)$ colouring of $\mathcal{G}(\mathbf{Z}^d)$, where k, δ_1 , and the span of the colouring are given by the colouring schema.

Definition 1. For $d \geq 1$, suppose $\sigma > 1, N \geq n(\sigma, d)$ are odd integers, and $T = \langle t_1, t_2, \dots, t_{d-1} \rangle$ is a non-decreasing sequence of $(d-1)$ positive, odd integers. Then (σ, T, N) is a colouring schema for \mathbf{Z}^d , denoted \mathcal{S}_d , iff

1. for each i , $1 \leq i < d$, $\sigma \leq t_i \leq N$, and
2. for all $X = (x_0, \dots, x_{d-1}) \in \mathbf{Z}^d$, $X \neq \vec{0}$,

$$\sum_{i=0}^{d-1} |x_i| < \sigma \implies \left(x_0 + \sum_{i=1}^{d-1} x_i \cdot t_i \right) \bmod N \neq 0.$$

Exhaustive verification proves the following proposition that asserts the existence of a colouring schema for \mathbf{Z}^3 .

Proposition 1. *The triple given by $\sigma = 5$, $T = (5, 19)$, and $N = 27$ is a colouring schema for \mathbf{Z}^3 . \square*

We define in Equation (11) the coloring scheme C_d , based on a colouring schema for \mathbf{Z}^d , $\mathcal{S}_d = (\sigma, T = \langle t_1, \dots, t_{d-1} \rangle, N)$. For each d , define a function $g_d(x, N)$ as:

$$g_d(x, N) = \begin{cases} \frac{x}{2}, & \text{if } x \text{ is even;} \\ \frac{x+N}{2}, & \text{otherwise.} \end{cases}$$

$$C_d(x_0, 0, \dots, 0) = g_d((x_0 \bmod N), N).$$

$$C_d(x_0, x_1, \dots, x_i, 0, \dots, 0) = C_d(x_0 - x_i \cdot t_i, x_1, \dots, x_{i-1}, 0, \dots, 0). \quad (11)$$

In the following lemma we observe some useful properties of the colouring of $\mathcal{G}(\mathbf{Z}^d)$ defined by Equation (11). We use these properties in Theorem 5 below.

Lemma 8. *Suppose C_d is used to colour \mathbf{Z}^d based on a colouring schema $\mathcal{S}_d = (\sigma, T = \langle t_1, \dots, t_{d-1} \rangle, N)$. Then,*

1. *The colours used by C_d are exactly the set $\{0, \dots, N-1\}$.*
2. *$C_d(x, 0, \dots, 0) = C_d(y, 0, \dots, 0) \iff |x - y| \bmod N = 0$.*
3. *Suppose $P = (p_0, p_1, \dots, p_{d-1})$ and $Q = (q_0, q_1, \dots, q_{d-1})$ are vertices in $\mathcal{G}(\mathbf{Z}^d)$ such that for each i , $1 \leq i < d$, $p_i = q_i$. Then, $|C_d(P) - C_d(Q)| = |C_d((p_0 - s) \bmod N, 0, \dots, 0) - C_d((q_0 - s) \bmod N, 0, \dots, 0)|$, where $s = \sum_{i=1}^{d-1} p_i \cdot t_i$.*
4. *Suppose $P = (p_0, p_1, \dots, p_{d-1})$ and $Q = (q_0, q_1, \dots, q_{d-1})$ are vertices in $\mathcal{G}(\mathbf{Z}^d)$ such that $p_k \neq q_k$, for some $1 \leq k < d$, and for each i , $0 \leq i (\neq k) < d$, $p_i = q_i$. Then,*

$$|C_d(P) - C_d(Q)| = |C_d((p_0 - s_p) \bmod N, 0, \dots, 0) - C_d((q_0 - s_q) \bmod N, 0, \dots, 0)|,$$

$$\text{where } s_p = \sum_{i=1(\neq k)}^{d-1} p_i \cdot t_i + p_k \cdot t_k, \text{ and } s_q = \sum_{i=1(\neq k)}^{d-1} p_i \cdot t_i + q_k \cdot t_k.$$

5. *For each i, j , $0 \leq i < j < N$, if $(j - i)$ is odd then $|C_d(i, 0, \dots, 0) - C_d(j, 0, \dots, 0)| \geq \frac{N-(j-i)}{2}$.*

Proof. Parts 1, 2, 3, and 4 are immediate from the definition of C_d in Equation (11). Suppose $j = i + 2k + 1$ such that $0 \leq i < j < N$. (In the rest of this proof, for convenience, and without loss of generality, we will use $C_d(x)$ for $C_d(x, 0, \dots, 0)$.) Part 5 can be proved by considering the two cases: i even and i odd, and using the definition of the function g_d to get the difference in the colour assignment of i and j . \square

Theorem 5. *For $d \geq 1$, given a colouring schema $\mathcal{S}_d = (\sigma, T = \langle t_1, \dots, t_{d-1} \rangle, N)$, C_d is an $L(\delta_1, \vec{1}_{\sigma-2})$ colouring of \mathbf{Z}^d where $\delta_1 = \frac{N-t_{d-1}}{2}$. The span of this colouring is N .*

Proof. We need to verify that C_d satisfies the channel separation constraint and the co-channel reuse constraint.

Consider any two neighbouring vertices, $P = (p_0, \dots, p_{d-1})$ and $Q = (q_0, \dots, q_{d-1})$, in $\mathcal{G}(\mathbf{Z}^d)$. Clearly, then, either p_0 and q_0 differ by one, or for some i , $1 \leq i < d$, p_i and q_i differ in one. In the former case, using parts 3 and 5 of Lemma 8, we have that the separation between the colours assigned to these two points is at least $\frac{N-1}{2}$. In the latter case, using parts 4 and 5 of Lemma 8, and since t_{d-1} is the largest value in T , we have that the separation between the colours assigned to these two points is at least $\frac{N-t_{d-1}}{2}$.

Since \mathcal{S}_d is a colouring schema for \mathbf{Z}^d , it satisfies property 2 in Definition 1. This property of \mathcal{S}_d along with Part 2 of Lemma 8 ensures that if two vertices are assigned the same colour then the distance between them is at least N , the reuse distance. \square

Now the following is an immediate consequence of Proposition 1 and Theorem 5.

Corollary 1. *The colouring schema for \mathbf{Z}^d given in Proposition 1 above witnesses an $L(4, 1, 1, 1)$ colouring of $\mathcal{G}(\mathbf{Z}^3)$. The span of the colouring is $N = 27$. \square*

We end this section with the following observation about the efficiency of the above assignment algorithms.

Lemma 9. *The running times of the above algorithms for colouring $\mathcal{G}(\mathbf{Z}^d)$ are $O(d)$.*

Proof. Consider the general colouring scheme C that uses the translation function t_i to colour a vertex $P = (x_0, x_1, \dots, x_{d-1})$. The colour assigned to P is given by: $C(P) = C(x_0 - \sum_{i=1}^{d-1} x_i \cdot t_i, 0, \dots, 0)$. Clearly, the assignment time is $O(d)$. \square

5 Conclusions and Open Problems

We investigated colorings in higher dimensional square grids and presented optimal $L(2, 1)$ and $L(2, 1, 1)$ colourings for square grids in all dimensions $d \geq 1$. Treated as lattices, certain lower dimensional cellular grids are subsets of d -dimensional square grids, and certain lower dimensional square grids are subsets of d -dimensional cellular grids. We use this property to establish the existence of channel assignment algorithms for each kind of grid (square/cellular) based on algorithms for the other kind of grid (cellular/square). We also introduce the notion of a colouring schema for the d -dimensional square grid, and an algorithm that, given the colouring schema, assigns colours to the grid satisfying the schema constraints.

Several interesting open questions arise from the work presented here. We list a few of them here: (1) Find optimal, or near-optimal, colourings for higher dimensional cellular grids. (2) Find optimal, or near-optimal, colourings for d -dimensional square grids for reuse distances larger than 4. (3) Find colouring schema \mathbf{Z}^d for various values of reuse distance and dimension.

References

- [1] R. Battiti, A. A. Bertossi, and M. A. Bonuccelli. Assigning codes in wireless networks: bounds and scaling properties. *Wireless Networks*, 5:195–209, 1999.
- [2] Alan A. Bertossi, Cristina M. Pinotti, and Richard B. Tan. Efficient use of radio spectrum in wireless networks with channel separation between close stations. In *Proceedings of the DIAL M Workshop*, pages 18–27, 2000.
- [3] Alan A. Bertossi, Cristina M. Pinotti, and Richard B. Tan. Channel assignment with separation for special classes of wireless networks: grids and rings. In *Proceedings of IPDPS*, 2002. (to appear).
- [4] Hans L. Boedlander, Ton Kloks, Richard B. Tan, and Jan van Leeuwen. λ -coloring of graphs. In *Proceedings of STACS*, pages 395–406, 2000.
- [5] J. Conway and N. Sloane. *Sphere Packings, Lattices and Groups*. Springer Verlag, second edition, 1993.
- [6] J. R. Griggs and R. K. Yeh. Labeling graphs with a condition at distance 2. *SIAM J. Disc. Math.*, pages 586–595, 1992.
- [7] W.K. Hale. Frequency assignment: Theory and application. *Proceedings of the IEEE*, 68:1497–1514, 1980.
- [8] Robert A. Murphey, Panos M. Pardalos, and Mauricio G.C. Resende. Frequency assignment problems. In *Handbook of Combinatorial Optimization*. Kluwer Academic Press, 1999.
- [9] Dayanand S. Rajan and Anil M. Shende. A characterization of root lattices. *Discrete Mathematics*, 161:309–314, 1996.